

Service manual

--RD-297



Ningbo R. D. C Office Equipment Co., Ltd

I . Machine Structure

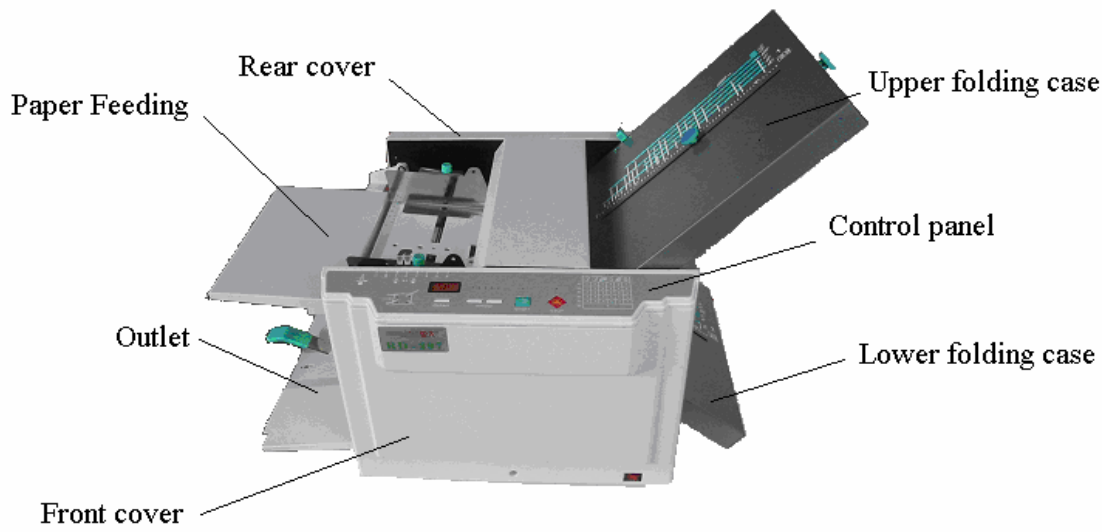

Fig.1

II . Operation Mechanism

1. Working theory of the folding machine

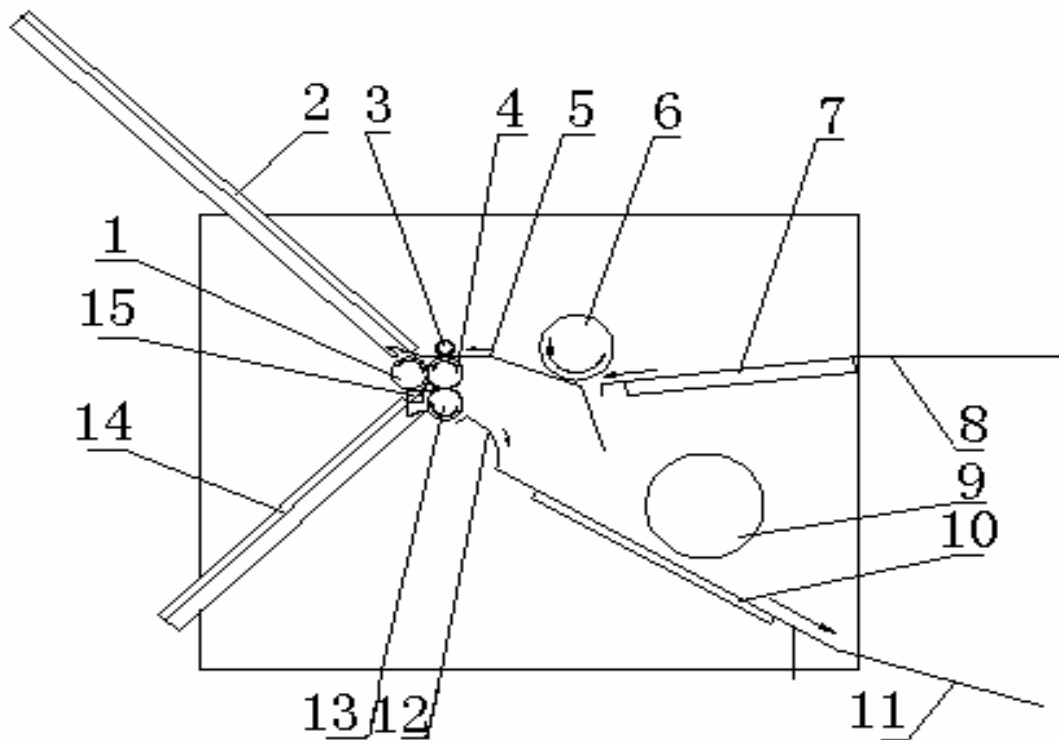

Fig.2

1	First fold driven shaft	9	Outlet pulley
2	Upper folding case	10	Outlet support plate
3	Driven shaft	11	Outlet sheet tray
4	Driving shaft	12	Upper brocket
5	Neaten plate	13	Second fold driven shaft
6	Paper roller	14	Lower folding case
7	Paper Feeding support plate	15	Quadrate shaft
8	Paper feeding tray		

The working theory of the folding machine is showed in Fig.2.

The sheet on the paper feeding support plate(7) is pushed by roller(6) to reach neaten plate(5).Being driven by driving shaft(4)and driven shaft(3), the sheet is sent to upper folding case(2).And then being driven by first fold driven shaft(1), the driving shaft(4) and the quadrate shaft(15) together to complete the first folding. The first folded sheet goes through the outlet pulley(9) via the driving shaft(4) and second fold driven shaft(13) along outlet plate(10) to be ejected out when there is only the first folding is needed. Or after the first fold, the folded sheet is sent to the lower folding case (14) by the operation of the driven shaft (1), the driving shaft (4) and the quadrate shaft (15) together to complete the second fold, then goes through the driving shaft (4) and driven shaft (3) along the outlet sheet tray (11) to be ejected, the whole folding process also can be completed successfully.

2. Driving Mechanism

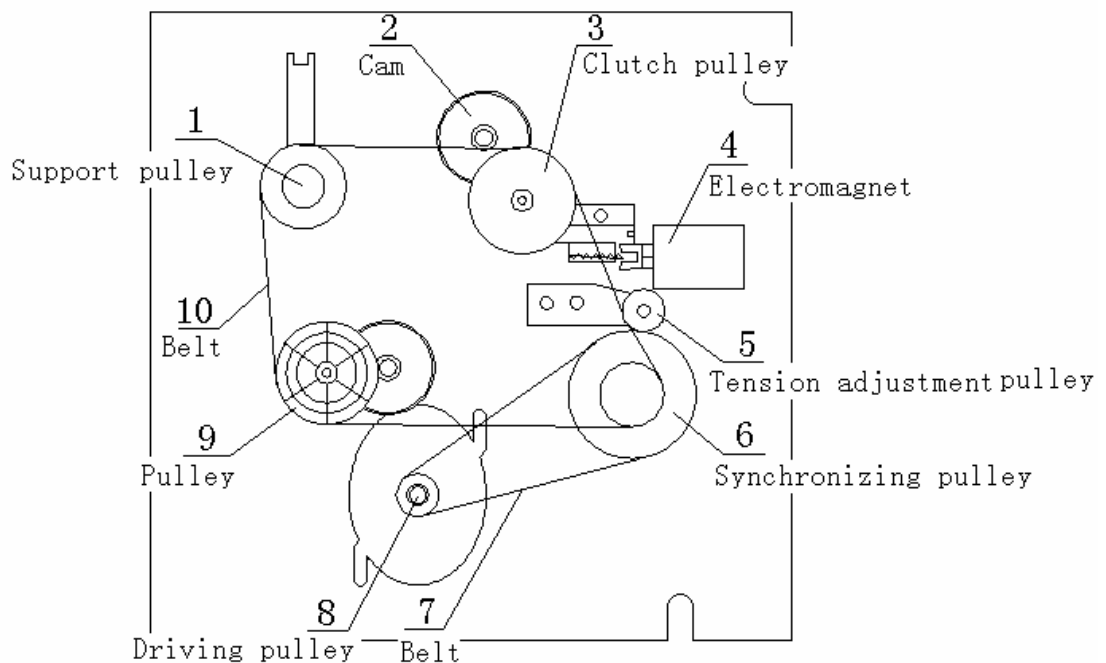

Fig.3

The transmission theory is figured out in Fig.3.

The motor with the pulley(8)drives the driven pulley(6) via the belt(7).And then the driven pulley(6) via the belt(10) drives the shafts of the pulleys (1),(3)and(9) to work.. Tension adjustment pulley (5) can be used to adjust the belt. The clutch installed on the pulley (3) works with electromagnet (4), controls the paper feeding driving shaft to drive the sheet to the right position.

III.Control panel

1. Panel functions and operation

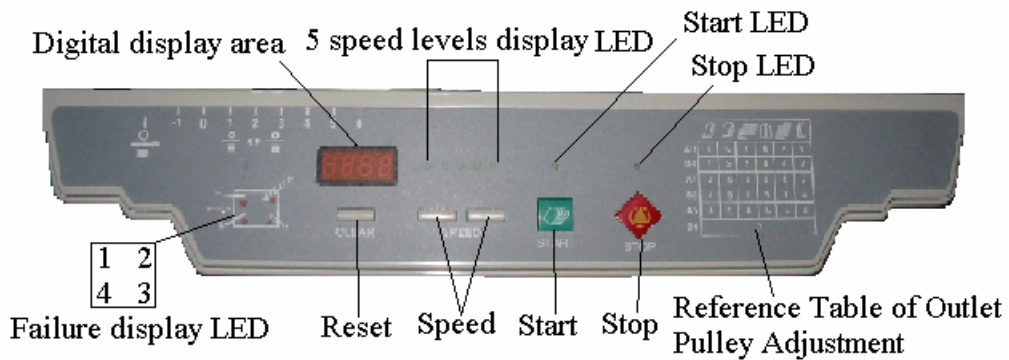

Fig.4

Function keys description

Part/Item	Function
Digital Display	Displays the codes of the number of sheets currently folded, machine status and the number of totally folded sheets of history.
Reset	Press “Reset”, digital display shows “0”. When display “0”, press “Reset”, display machine status as: H-XXXX×10K sheets, L-XXXX ×1 sheets.
Speed	Press the right key, speeds up, LED display goes up. Press the left key, slows down, LED display goes down.
Start	Press “Start”, Machine starts operation, relative LED shall be on
Stop	a) Press “Stop”, machine stops working b) Press “Stop”, push out the paper in the machine
Failure display LED 1	On, shows that the paper feeding adjust bar is not pressed down or paper feeding tray is empty.
Failure display LED 2	On, shows that the upper folding case is not installed
Failure display LED 3	On, shows that the lower folding case is not installed
Failure display LED 4	On, shows paper jam when the machine is running

2. Machine Function Inspection

After installation, enter “HELP” function by pressing and holding the “Start” key, turn the power on, after “beep”, release “Start” key. Digital display shows “H0”, the machine enters “HELP” program. (Press “Stop” to exit).

Then press the right/left “speed” keys to select the help code (0-5), press “Start” key to enter help code and press “Stop” to return.

The following are the functions of the help codes.

Help code	Bit	Function
H 0		Test the digital tube and the LED
H 1	1	The counter sensor: “0” light mask, “1” light through
	2	The encoding sensor: “0” light mask, “1” light through
	3	The paper feeding sensor: “0” light mask, “1” light through
H 2	1	The first folding case: “0” case ready, “1” no case
	2	The second folding case: “0” case ready, “1” no case
H 3	1	Electromagnet: “0” on, “1” off (Press “Start” to test, “Stop” to return)
H 4		Press “Start”, the motor starts running. Press the right or left speed key to adjust the motor’s rotation speed, press “Stop” key to return.

Having finished the first three steps or maintained, enter the test status to check if the machine is connected right or not.

IV. Paper feeding system



Paper holding plate

Fig.5 Paper holding plate



Pressure adjustment plate
for paper supporting↵

Fig.6 Pressure adjustment plate for paper supporting



Pressure adjusting dial↵
for paper standing↵

Fig.7 Pressure adjusting dial for paper stranding

- (1) Load the paper neatly and properly for folding with holding plates.(See Fig.5)
- (2) Use pressure adjustment bar to adjust the paper holding pressure according to the type of paper for folding. (See Fig.6)
- (3) Use pressure adjustment dial for paper roller pressure adjustment according to the condition of the sheets to be folded. (See Fig.7)

V.Folding system

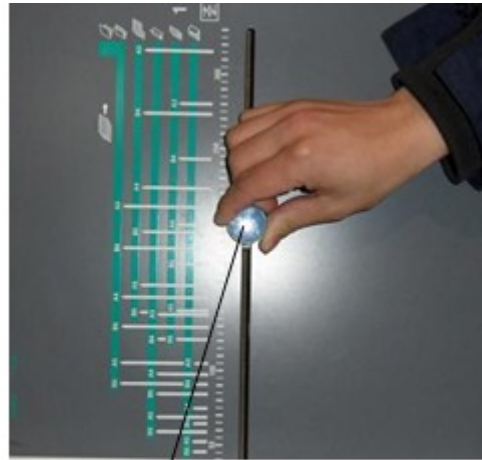

Rough Adjustment ↵

Fig.8 Rough adjustment

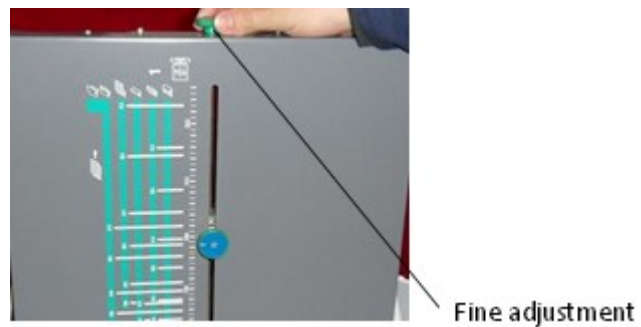

Fine adjustment

Fig.9 Fine adjustment

1. Upper/lower folding case adjustment

- 1) Pull up the rough adjustment knob, slide it to the wanted position (See Fig.8)
- 2) Rotate the fine adjustment knob to adjust it to the correct position during the trial-folding(See Fig.9)

Refer to the following figures to gain the detail operation information.

2. Upper folding case fine adjustment

Folding type	Single folding	Double folding	Irregular folding	Envelope folding	Accordion folding	Pamphlet folding
Size A beyond	Rotate right	Rotate right	Rotate right	Rotate right	Rotate right	Rotate right
Size A short	Rotate left	Rotate left	Rotate left	Rotate left	Rotate left	Rotate left

3. Lower folding case fine adjustment

Folding type	Single folding	Double folding	Irregular folding	Envelope folding	Accordion folding	Pamphlet folding
Size B beyond	Rotate right	Rotate right	Rotate right	Rotate right	Rotate right	Rotate right
Size B short	Rotate left	Rotate left	Rotate left	Rotate left	Rotate left	Rotate left

VI.Outlet system

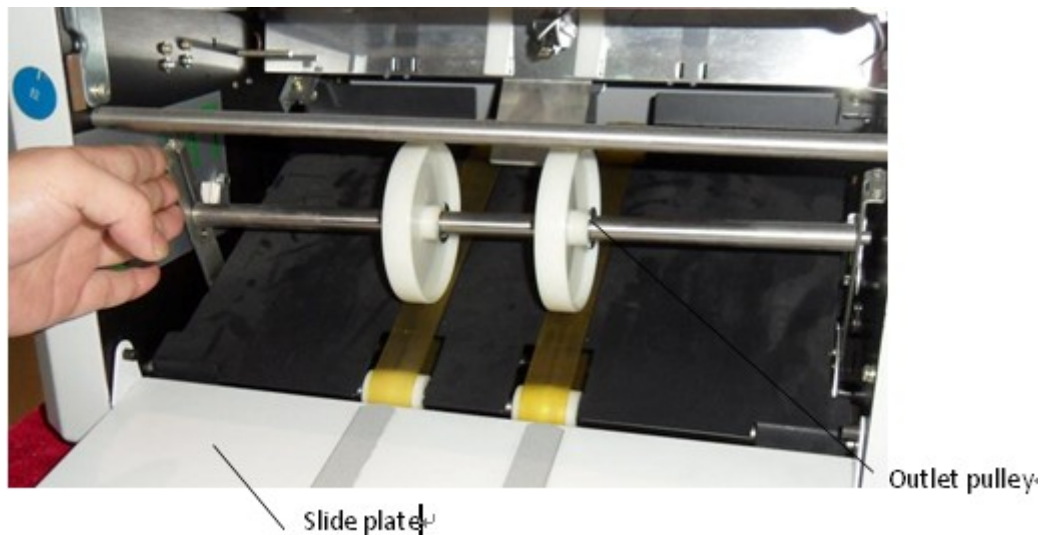

Fig.10 Outlet pulley

Regulate the slide plate position according to the paper specification and the folding type, and so make the paper put out successfully.

VII. Routine maintenance

- 1) Please cover the machine properly to keep it away from dust when stop using it.
- 2) Clean the enclosure, roller and cushion with alcohol or wet soft cloth in time.
- 3) Before cleaning, make sure to turn off the power and pull out the power plug.
- 4) Please use the alcohol detergent when cleaning the cover, never use other kinds of detergent with corrosive, and avoid defacing the plastic cover or erasing the characters on the cover.

VIII. Troubleshooting Table

	Faults	Cause	Solution
1	Paper Feeding tray empty with LED "1"on	No paper paper on the workbench	Add more paper for folding
2	No Paper Outlet with LED "4"on	<ol style="list-style-type: none"> 1. Paper jam 2. The paper jam sensor failure 	<ol style="list-style-type: none"> 1. Carefully remove the two folding plates, and jog the "stop" key, and so the jammed paper can be taken out 2. Clear the stain on the sensor
3	Paper feeding slip	<ol style="list-style-type: none"> 1. The roller or the roller rubber has been contaminated. 2. The paper is too slipping. 3. The driving V-belt is slip. 4. The roller or the roller rubber has been worn and torn. 5. The one-way driving device of the synchrowheel is failure. 	<ol style="list-style-type: none"> 1. Bedew the soft cloth with alcohol to clean the surface. 2. Select the proper paper. 3. Adjust the V-belt with the strain pulley. 4. Replace the worn and torn parts. 5. Replace the synchrowheel parts.
4	Paper jam	<ol style="list-style-type: none"> 1. Maybe there are paper segments in the paper path. 2. The paper is too thin. 3. The paper is not placed at the right position. 4. Folding cases are not mounted correctly. 5. The plastic roller is contaminated. 	<ol style="list-style-type: none"> 1. Clean up the paper segments. 2. Select the proper paper. 3. Place the paper correctly. 4. Install folding case right. 5. Clean up the roller with a soft cloth with alcohol.
5	The folding parts create creases.	<ol style="list-style-type: none"> 1. There are paper segments on the roller. 	<ol style="list-style-type: none"> 1. Clean up paper segments or other stain on the roller.

		2. Roller pressure is too high. 3. The paper is not proper.	2. Adjust roller pressure. 3. Select the proper paper.
6	No outlet after folding.	Wrinkle on the folded sheets.	Make the rough adjustment of the lower folding case to the highest position.
7	Folded sheets are not neat.	Roller pressure is too low.	Adjust the roller pressure.
8	Interrupted output of folded sheets.	1. Outlet roller position incorrect. 2. Paper segments in the sheet counter sensor.	1. Adjust the position of the outlet roller. (Refer to the Fig.4 of the control panel). 2. Clean up the paper segments.
9	No display with power on.	1. The fuse is gone. 2. Power supply failure.	1. Replace the fuse. 2. Replace the power supply.
10	Paper feeding speed is not stable.	The mounting screws of the electromagnet are loose.	Tighten the electromagnet screws.